

## Coolflow Cooling Solutions

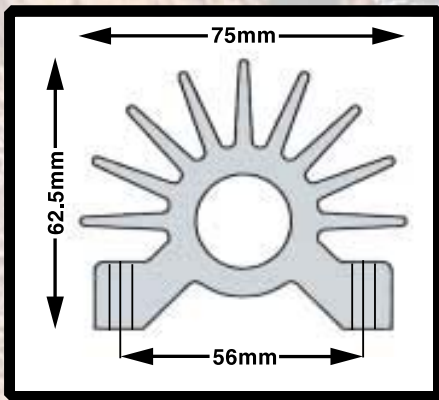

### Why your trucks needs a COOLFLOW fluid cooler

- Today's trucks run hot with higher engine bay temperatures.
- Hose and seal life is extended.
- Less downtime due to heat related fluid problems.
- Can be used to cool engine fuel, differential and gearbox oils.
- Significant improvement in fuel economy can be achieved in certain circumstances

### What's special about the Hydrosteer COOLFLOW

- Low back pressure design.
- Mechanically strong, resists stone damage.  
Easy mounting, almost anywhere.
- No clog design, can run in dusty areas.
- Available in a range of standard lengths.
- Custom lengths available for special applications.



(Typical Fuel Cooler Installation)

# Hydrosteer

Technically Superior

Melbourne (Head Office) Phone: (03)9762 8855  
4, Newcastle Road, Bayswater Vic 3153

Perth Phone: (08) 9493 5885  
Unit 1 & 2 / 137 Kelvin Road, Maddington WA 6109

Laverton Phone: (03) 9314 5000  
Unit 1 / 32 Little Boundary Road Laverton Nth. Vic 3026

[www.hydrosteer.com.au](http://www.hydrosteer.com.au)